

6004

N1955

In Reply Refer To: RP-2-1

JAN 2 1985

Sequent Energy E & P Inc.
Attention: Mr. James G. Floyd
1001 Fannin, Suite 1700
Houston, Texas 77002

Gentlemen:

Reference is made to your Initial Development Operations Coordination Document (DOCD) received December 21, 1984, for Leases OCS-G 6004 and 3043, Blocks 828 and 831, respectively, Mustang Island Area. This DOCD includes the activities proposed for Platform A and seven wells.

In accordance with 30 CFR 250.34, revised December 13, 1979, and Notice to Lessees and Operators No. 34-1, this DOCD has been determined to be complete as of January 2, 1985, and is now being considered for approval.

Your control number is 4-1955 and should be referenced in your communication and correspondence concerning this DOCD.

Sincerely yours,

(Orig. Sgd.) D.W. Solanas

D. W. Solanas
Regional Supervisor
Rules and Production

CB

cc: Lease OCS-G 6004 (OPS-2-3) (FILE ROOM)
Lease OCS-G 3043 (OPS-2-3) (FILE ROOM)
OPS-2-5 w/Public Info. Copy of the DOCD (PUBLIC RECORDS ROOM)
00-3

A t:gcw:12/27/84 Disk 3a

RECORDS SECTION
PROJECT A

85 JAN 8 AM 1:52

RECEIVED

"Public Information"
MINERAL MANAGEMENT SERVICE

DEC 21 1984

RULES AND PRODUCTION

SEAGULL ENERGY E&P INC.

A Subsidiary of Seagull Energy Corporation
1001 Fannin, Suite 1700 • Houston, Texas 77002 • (713) 951-4700

December 19, 1984

Department of the Interior
Minerals Management Service
P. O. Box 7944
Metairie, Louisiana 70010

Attention: D. W. Solanas
Regional Supervisor
Rules and Production

RE: OCS-G 6004, Block 828 ⁺³⁰⁴³ +831
Mustang Island Area
Development Operations
Coordination Document

Gentlemen:

In accordance with the provisions of Title 30 CFR 250.34-1, Seagull Energy E & P, Inc. hereby submits for your approval eight (8) copies of a Development Operations Coordination Document for Mustang Island Area Block 828, Federal lease OCS-G 6004. Five (5) copies are considered Proprietary Data and three (3) copies are Public Information.

Seagull Energy anticipates starting development activities approximately February 1, 1985.

Should any additional information be required, please contact Kathy Saunders at (713) 558-0607.

Very truly yours,

James G. Floyd/KS

James G. Floyd
President

JGF/KS/jd

Enclosures

DEVELOPMENT OPERATIONS COORDINATION DOCUMENT

LEASE OCS-G 6004, BLOCK 828

MUSTANG ISLAND AREA

OFFSHORE, TEXAS

In compliance with 30 CFR 250.34 and the Notice to Lessees 84-1 of February 10, 1984, the following information is submitted for the Development Operations Coordination Document (DOCD).

1. Description of Development and Production Activity

A total of seven (7) wells will be involved in the development and production activities for Mustang Island Block 828 (Figure 1). One well was included in the Plan of Exploration. Well #1 (A-1) is temporarily abandoned.

Six additional wells (A-2 thru A-7) are proposed for drilling under the Development Operations Coordination Document. Development and production activities for all wells will occur from proposed Platform "A", located in Mustang Island Block 828. Platform "A" is a 4-pile, 9-slot platform which will be positioned at the location of Well No. 1 (A-1) (860' FSL & 5938' FEL) in Mustang Island Block 828.

2. Schedule

The development phase will commence approximately February 1, 1985. The estimated time to complete the work proposed in the Development Operations Coordination Document is approximately November, 1985. Production is estimated to be 60 MMCF/D.

3. Location of the Lease Block, Platform, Pipeline and Onshore Facilities

Mustang Island Block 828 is located approximately 35 miles from the nearest shoreline off the Texas coast. A location map of Block 828 relative to the shoreline is given in Figure 2.

Platform "A" will be installed over Well No. 1 (A-1) located 860' FSL & 5938' FEL of Mustang Island Block 828.

Seagull Energy will use the existing onshore base facilities of Dresser Industries located at Harbor Island, Texas. This base serves the operations. A crew boat and supply boat will each make 7 trips/week during drilling operations and 1 trip per week during production operations. Helicopter trips (10.5 per week during drilling and 7 per week during production) will originate from the heliport of Omniflight in Corpus Christi, Texas. The onshore activities associated with Mustang Island Block 828 should not result in any increase in the size or number of onshore support and storage facilities or land and personnel requirements.

The life of reserves in Block 828 is approximately 18 years. Estimated production is approximately 60 MMCF/D.

4. Geological and Geophysical Data

Figure 3 is the structure map which reflects the current interpretation of the subsurface geology in Blocks 828 and 831. This confidential data, which is submitted for use by authorized Minerals Management Service personnel only, is exempt from disclosure under the provisions of the Freedom of Information Act 5 U.S.C. 552.

Information on geological hazards and surface locations relative to anomalies was discussed in the Plan of Exploration. It should be noted during drilling operations of the No. 1 well, Seagull penetrated an anomaly between 1800-2000' with no indication of shallow gas.

The proposed BHL and TVD for each well is given below:

| <u>Well</u> | <u>Location</u> | <u>TVD</u> |
|-------------|---|------------|
| A-2 | Surf: 860' FSL & 5938' FEL of Block 828 | 6800' |
| A-3 | Surf: 860' FSL & 5938' FEL of Block 828 | 7000' |
| A-4 | Surf: 860' FSL & 5938' FEL of Block 828 | 7000' |
| A-5 | Surf: 860' FSL & 5938' FEL of Block 828 | 7000' |
| A-6 | Surf: 860' FSL & 5938' FEL of Block 828 | 6800' |
| A-7 | Surf: 860' FSL & 5938' FEL of Block 828 | 6800' |

5. Description of Platform and Pollution Prevention Equipment

Seagull Energy anticipates utilizing a jackup rig to drill the wells in Mustang Island Block 828.

Platform "A" will be a four-pile, nine-slot, two-level drilling/production platform designed to process production from the seven wells proposed in this DOCD. The location of Platform "A" is as follows:

860' FSL & 5938' FEL of Block 828

Latitude: 27° 26' 51.35"

Longitude: 96° 45' 42.487"

In accordance with OCS Order No. 8 and 9, applications showing the design, fabrication and plan of installation of the platform will be submitted to the Minerals Management Service for approval.

Seagull Energy E & P, Inc. currently has an Oil Spill Contingency Plan approved by the Minerals Management Service. This plan designates an Oil Spill Team consisting of Seagull personnel and contract personnel. This team's duties are to eliminate the source of any spill, remove all sources of possible ignition, deploy the most reliable means of available transportation to monitor the movement of a slick, and contain and remove the slick if possible. Seagull is a member of Clean Gulf Associates (CGA). The CGA has four permanent bases in Louisiana; at Venice, Grand Isle, Intracoastal City and Cameron and bases in Texas at Rockport and Galveston. Each base is equipped with fast response skimmers and there is a barge mounted high volume open sea skimmer based at Grand Isle, Louisiana. In addition to providing equipment, the CGA also supplies advisors for clean up operations.

Response time for a spill in Mustang Island Block 828 could vary from 4 to 8 hours depending upon the location of company operated work boats or work boats available for charter.

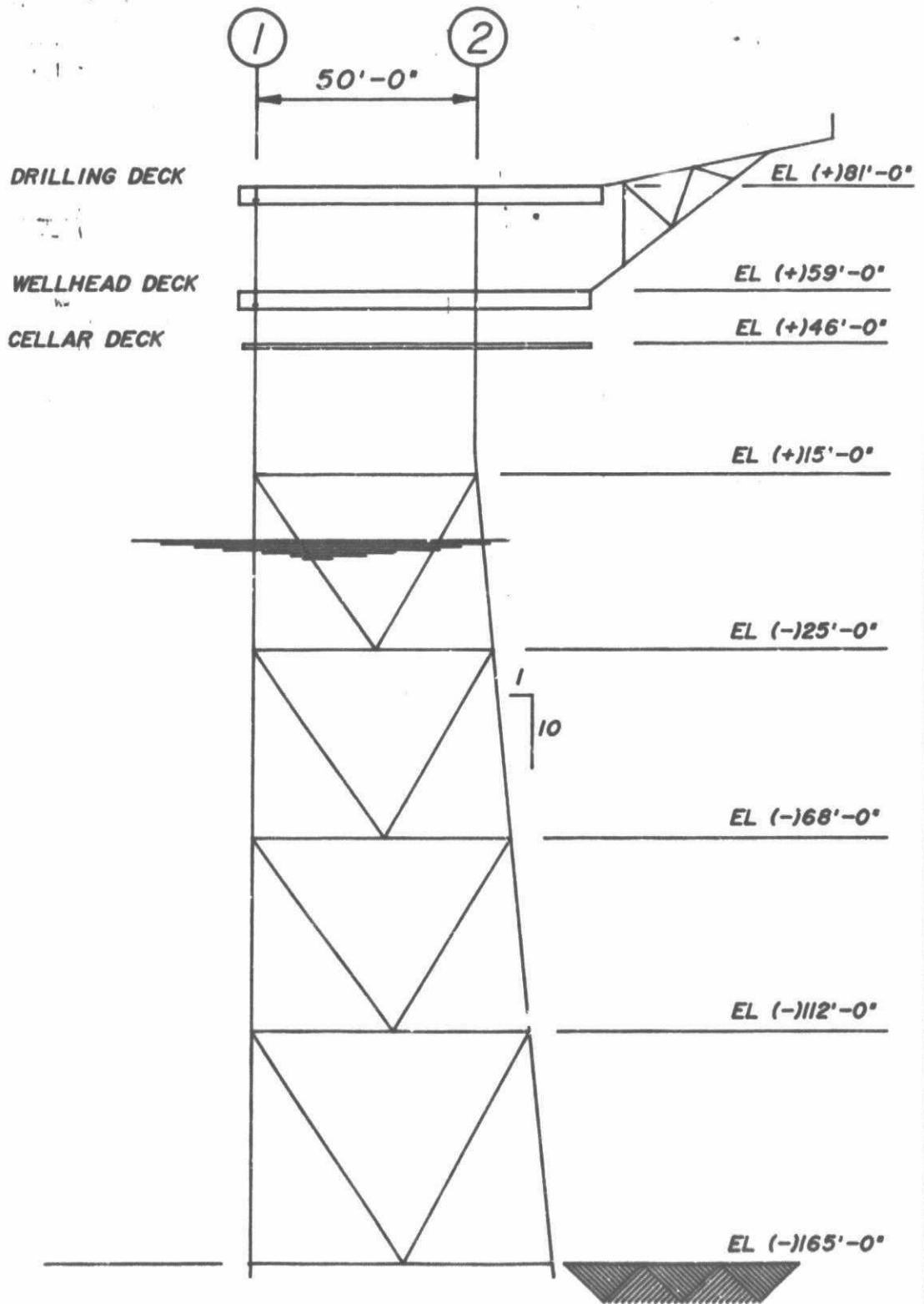

| | |
|------------|---|
| MC-0151 | Brown & Root, Inc. HOUSTON, TEXAS |
| SK-01 | ELEVATION ROW A |
| SHT 1 OF 1 | DRAWN BY _____ SCALE 1" = 35' DATE 11/30/84 |

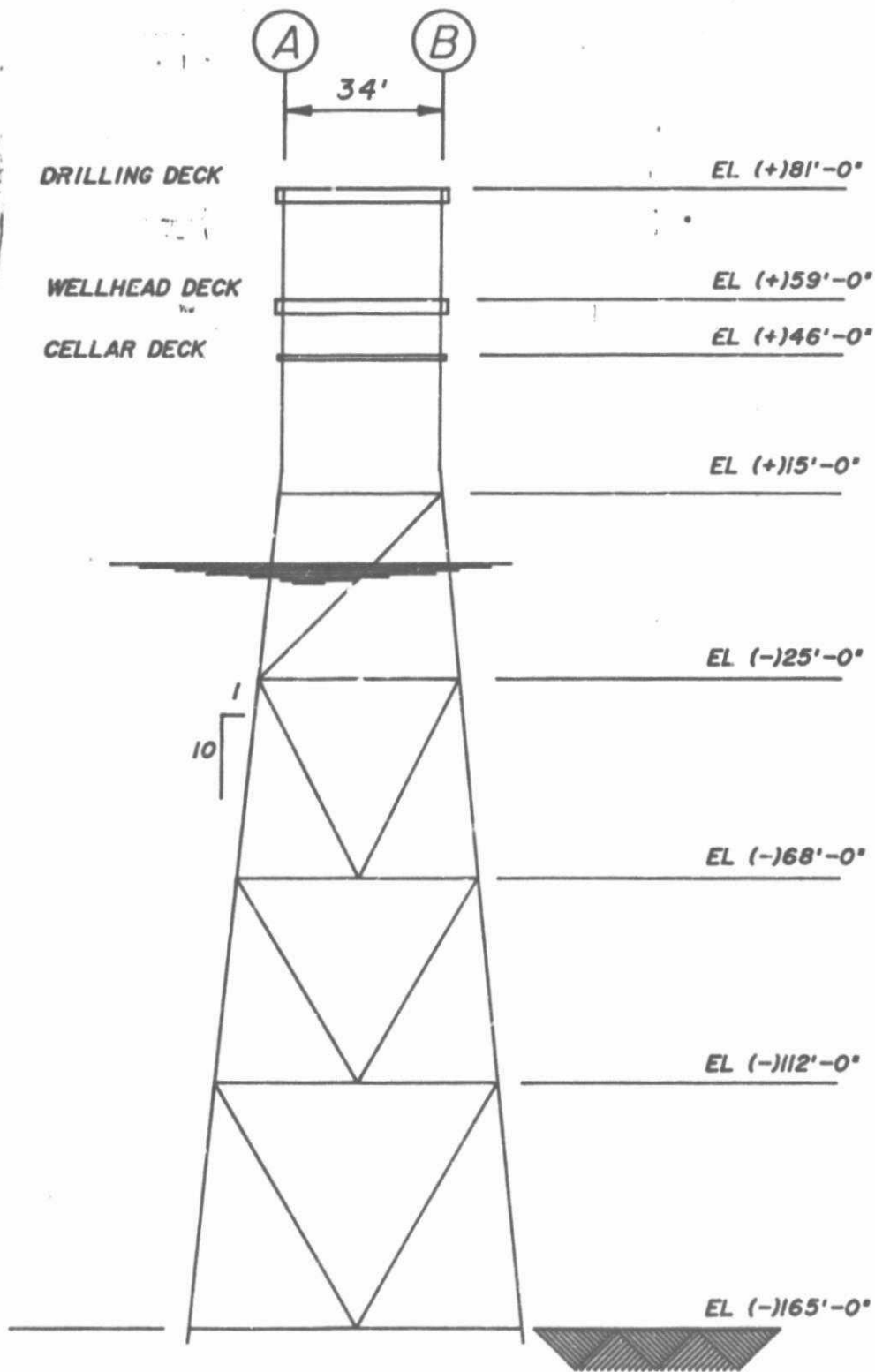

MC-0151

Brown & Root, Inc. HOUSTON, TEXAS

SK-02

ELEVATION ROW 1

SHT 1 OF 1

DRAWN BY _____

SCALE 1" = 35'

DATE 11/30/84

— Z — PLATFORM NORTH

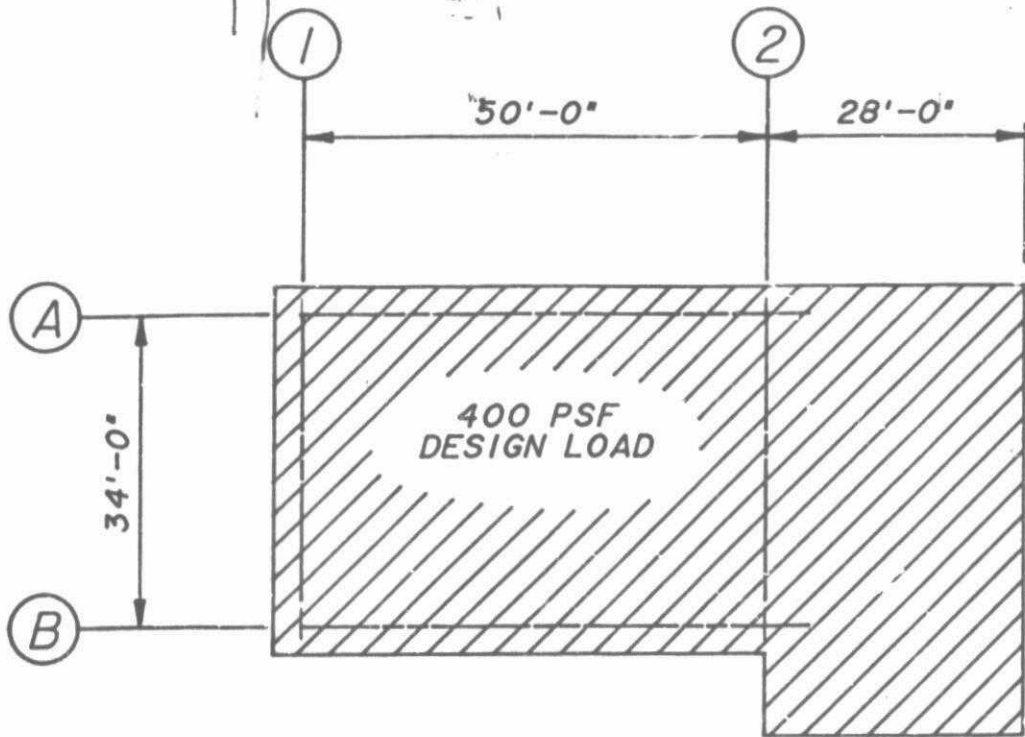

TOP OF DECK STEEL
ELEVATION (+)81'-0"

MC-0151

Brown & Root, Inc. HOUSTON, TEXAS

SK-03

DRILLING DECK PLAN

SHT 1 OF 1

DRAWN BY _____

SCALE 1" = 20'

DATE 11/30/84

PLATFORM NORTH

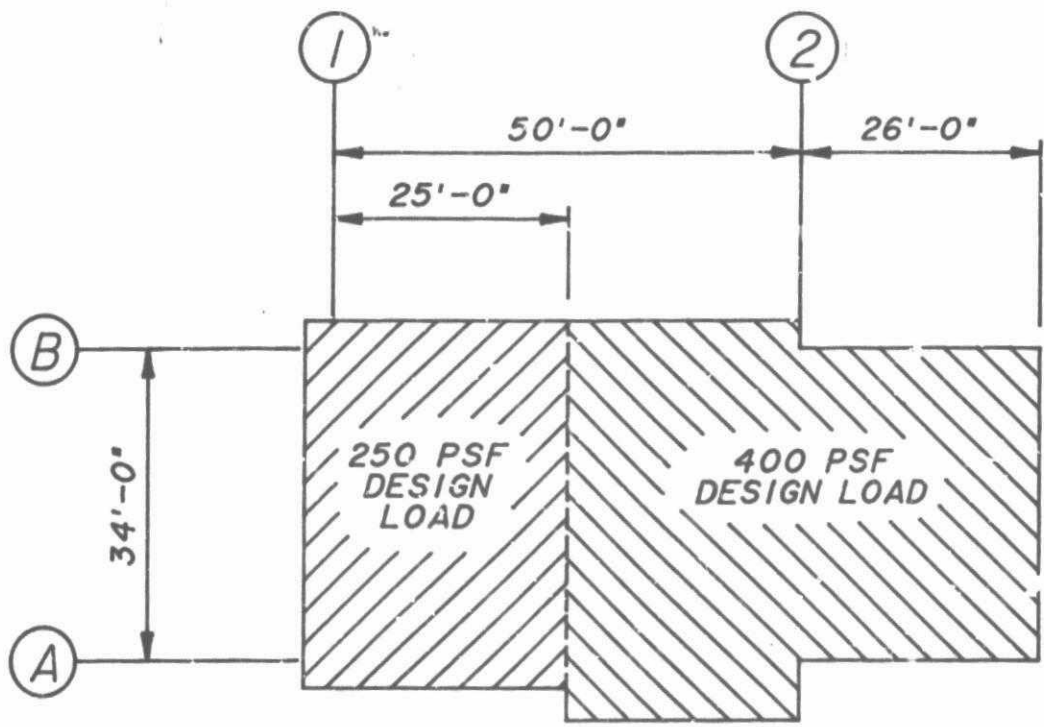

TOP OF DECK STEEL
ELEVATION (+)59'-0"

| | |
|------------|---|
| MC-0151 | Brown & Root, Inc. HOUSTON, TEXAS |
| SK-04 | WELLHEAD DECK PLAN |
| SHT 1 OF 1 | DRAWN BY _____ SCALE 1" = 20' DATE 12/07/84 |

PLATFORM NORTH

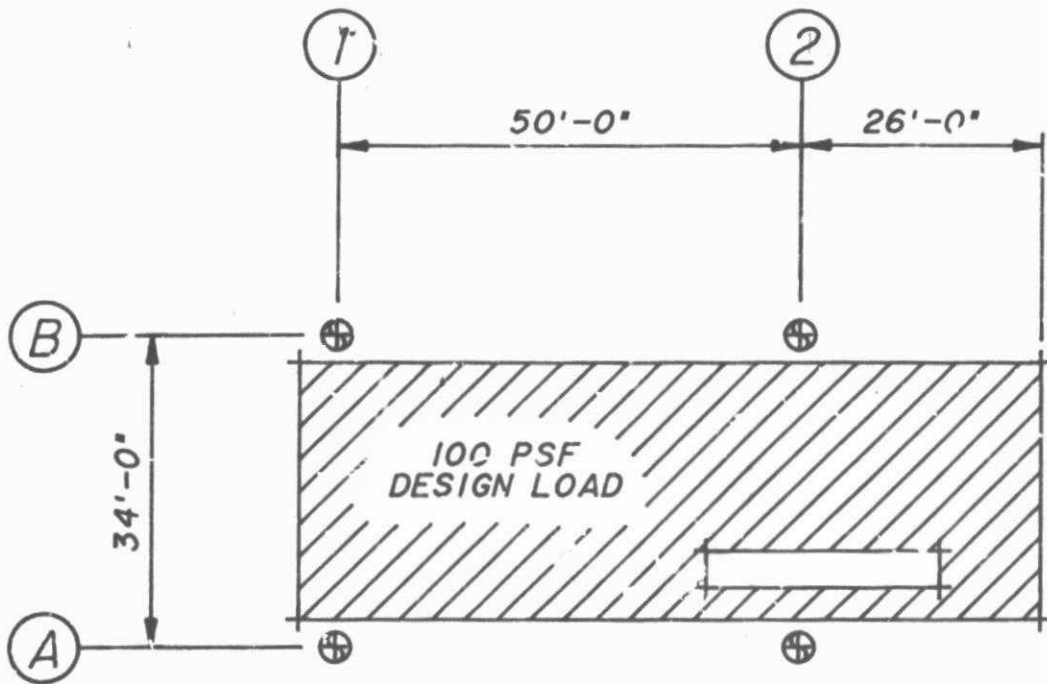

TOP OF GRATING
ELEVATION (+)46'-0"

MC-0151

Brown & Root, Inc. HOUSTON, TEXAS

SK-05

CELLAR DECK PLAN

SHT 1 OF 1

DRAWN BY _____

SCALE 1" = 20'

DATE 12/07/84

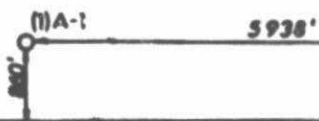

SEAGULL ENERGY E&P INC
MUSTANG ISLAND BLK 82
OFFSHORE TEXAS

FIGURE 1

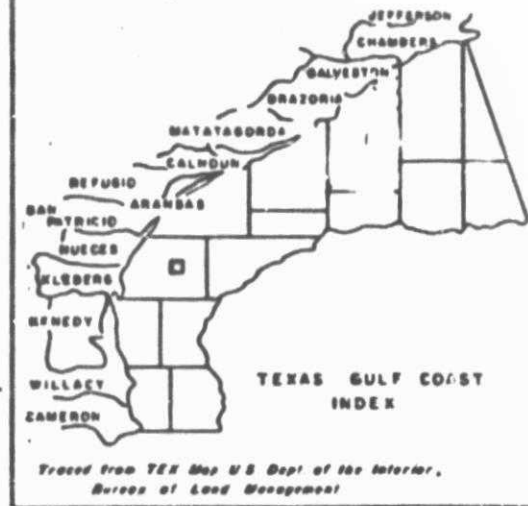

MUSTANG ISLAND AREA
OCS-G 6004

810

828

829

831

LOCATION PLAT
SCALE IN FEET

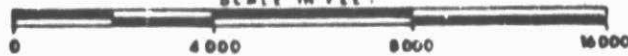

FIGURE 2

PROJECTED AIR EMISSION SCHEDULE FOR DEVELOPMENT/PRODUCTION PROJECTGeneral Information

| | |
|-----------------------------------|---|
| Location of Facility: | Mustang Island Block 828 OCS-G 6004 |
| Distance Offshore: | 35 miles |
| Name of Rig/Platform: | Jackup Rig/Platform "A" |
| Operator: | Seagull Energy E & P, Inc. 1001 Fannin, Suite 1700 Houston, Texas 77002 |
| Contact Person: | Ross Frazer, P.E. |
| Total Well Footage to be Drilled: | 46,700' |
| Date Drilling Will Begin: | February, 1985 |
| Date Drilling Will End: | May, 1985 |

Major Source (Offshore)

Power used aboard drilling vessel; approximate footage to be drilled 46,700'

| <u>Emitted Substance</u> | <u>Projected Emissions (lbs./day - Tons/Year) 1985*</u> |
|------------------------------|---|
| CO | (88) 9.2466 |
| SO ₂ | (28) 2.9421 |
| NOX | (413) 43.4309 |
| VOC | (33) 3.5024 |
| TSP | (29) 3.0822 |

* The drilling emissions and total well footage figures are maximum possible values for one year.

Minor Sources (Offshore)

| <u>Emitted Substance</u> | <u>Projected Emissions Tons/Year 1985</u> |
|------------------------------|---|
| CO | 1.8196 |
| SO ₂ | .0567 |
| NOX | .3486 |
| VOC | .1729 |
| TSP | .0787 |

Total All Sources (Tons/Year)

| <u>1985</u> | <u>CO</u> | <u>SO₂</u> | <u>NOX</u> | <u>VOC</u> | <u>TSP</u> |
|-------------|---------------|-----------------------|--------------|--------------|--------------|
| Major | 9.2466 | 2.9421 | 43.4309 | 3.5024 | 3.0822 |
| Minor | <u>1.8196</u> | <u>.0567</u> | <u>.3486</u> | <u>.1729</u> | <u>.0787</u> |
| Total | 11.0662 | 2.9988 | 43.7795 | 3.6753 | 3.1609 |

Onshore Sources

These should be about the same as minor sources unless new facilities are installed at the onshore base. No additional facilities are required or planned at this time.

Emission Exemption Determination

For CO: $E = 3400D^{2/3} = 3400 (35)^{2/3} = 36,380$ tons/year
 For NOX, VOC, TSP, SO₂: $E = 33.3D = 33.3 (35) = 1166$ tons/year

Predicted Production and Drilling Activity at Rig/Platform

Gas Production = 60 MMCF/Day
 Date Drilling will Begin = February, 1985
 Date Drilling Will End = November, 1985

Transportation Services

Supply Boats (3000 hp)
 Trips Per Week During Drilling - 7
 Trips Per Week During Production - 1
 Crew Boats (2500 hp)
 Trips Per Week During Drilling - 7
 Trips Per Week During Production - 1
 Helicopters
 Trips Per Week During Drilling - 10.5
 Trips Per Week During Production - 7

Methodology

Platform: Horsepower - hour method
 Boats: Horsepower - hour method
 Helicopters: Landing/Takeoff (LTO) cycle method)

References

- Production and Drilling - EPA 450/3-77-026 (June, 1977) - "Atmospheric Emissions from Offshore Oil and Gas Development and Production", pg. 81-116.
- Boats and Helicopters - EPA Report AP-42 - "Compilation of Air Pollutant Emission Factors", 3rd Edition, (August, 1977), pg. 116, 125 and 127.

Findings of Air Quality Review

As per DOI/MMS regulations, this facility is exempt from further air quality review as it has been determined that its operations will not have a significant adverse environmental impact on air quality.